

Montabert[®]

Hydraulic breakers
Silver Clip product range



Cutting edge technology dedicated to your productivity

Due to a unique advanced technology, Montabert hydraulic breakers have patented designs which offer high quality, high productivity and an unbeatable robustness.

Montabert is the best option to protect your investment:

- Maximum protection of the excavator thanks to its patented designs.
- Montabert breakers have a high resale value due to their long life features and reliability for which Montabert products are well-known.

Montabert hydraulic breakers combine power and versatility. Whether you are breaking rock or concrete, or are excavating, Montabert hydraulic breakers guarantee optimum performance for all your projects.

The Montabert Silver Clip range is designed to be used on all types of carriers from micro, mini, midi excavators to backhoe loaders. Robustness, power and adaptability are the key features of the Silver Clip product range, which will enable you to carry out several jobs easily with a single operator and a single machine on the construction site.

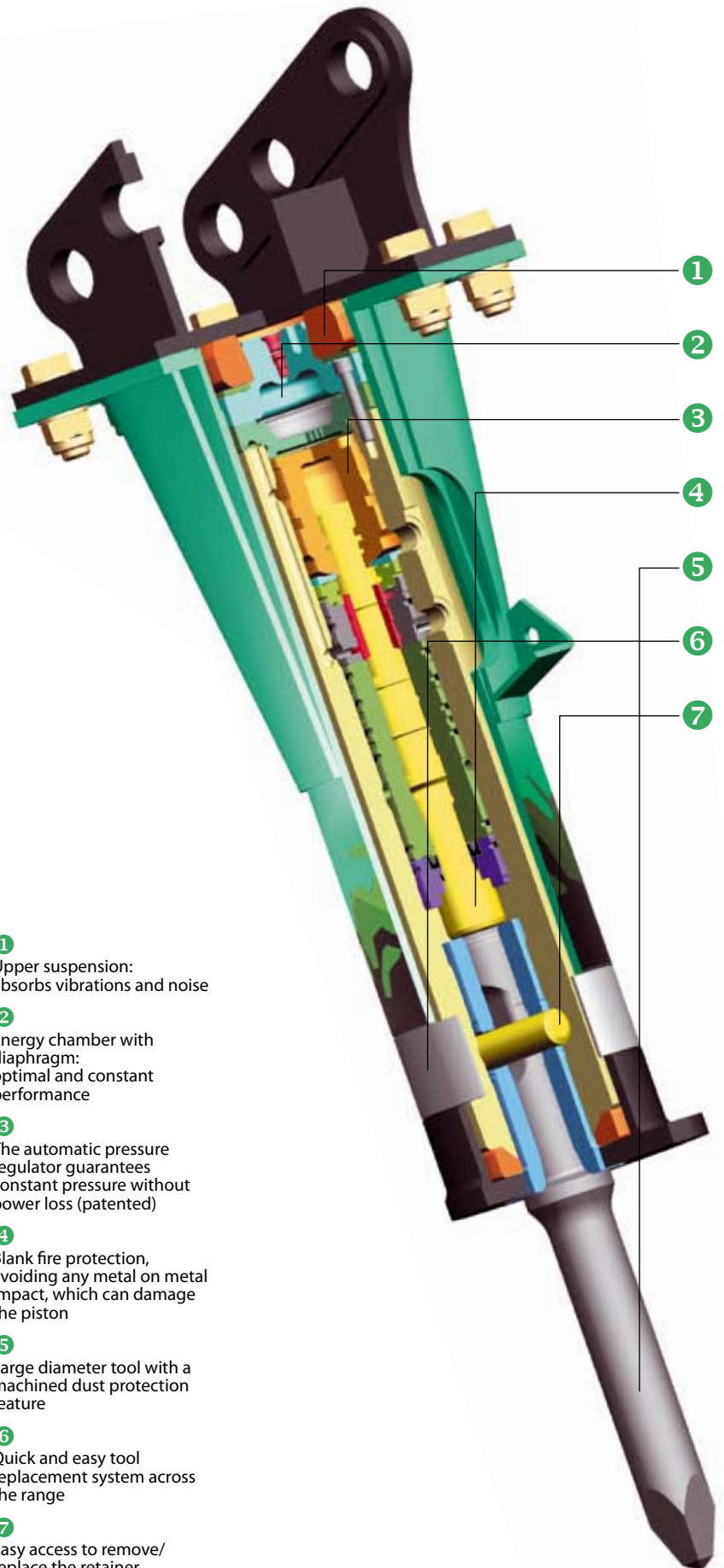

- 1 Upper suspension: absorbs vibrations and noise
- 2 Energy chamber with diaphragm: optimal and constant performance
- 3 The automatic pressure regulator guarantees constant pressure without power loss (patented)
- 4 Blank fire protection, avoiding any metal on metal impact, which can damage the piston
- 5 Large diameter tool with a machined dust protection feature
- 6 Quick and easy tool replacement system across the range
- 7 Easy access to remove/replace the retainer assembly and the tool bushing on all models



Unique features to maximize your profit

Robustness

- The Silver Clip range has a one piece body with no tie rods that could become stretched or broken, which could result in down time.
- The breaker has blank fire protection as standard to help minimize impact wear.
- Automatic pressure regulator in order to increase the lifespan of the breaker and to protect the excavator (patented)
- Fully enclosed casing and suspensions to absorb vibrations
- Diaphragm technology (maintenance-free, no refill needed)
- Fast removal of the tool bushing, which can be done on the job site (patented).

Power

- High power and performance: the energy ratio is higher than all current standards on this range of breakers, enabling optimal efficiency regardless of the material to be broken
- Large tool diameter
- An energy recovery device captures and recycles the rebound energy, making it available for the next impact stroke
- The patented pressure regulator automatically keeps a constant power, regardless of the hydraulic oil conditions (temperature, viscosity,...)

Flexibility

- Easily adaptable to a wide range of excavators while ensuring optimal performance (even with a high back-pressure)
- Its compact dimensions provide excellent ergonomics and make it fit for all work
- Standard noise isolation on the complete product range is designed for reduced noise on job sites

Specific options

- A compacting plate (Clip Ram) **8** and a Clip Bucket **9** are directly adaptable on the hydraulic breaker without having to modify any hydraulic connection or part (patented) (from SC 8 to SC 28)
- Easylub greasing (SC 50)
- Pressurization kit for underwater work (SC 50).

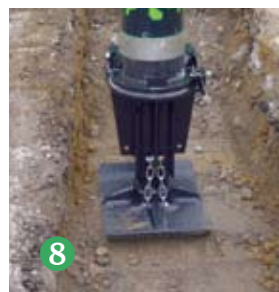

Specifications of the Silver Clip product range

Model		SC 6	SC 8	SC 12	SC 16	SC 22	SC 28	SC 36	SC 42	SC 50
Carrier weight	T	0.7 - 1.2	1 - 1.7	1.2 - 2.2	1.5 - 3.7	2.2 - 5.3	3 - 7.5	4.0 - 10.0	4.0 - 12.0	7.0 - 12.0
Weight with top bracket and tool	kg	65	90	110	150	225	275	365	445	498
Diameter of the tool	mm	37	45	47	55	65	72	76	84	94
Working length of the tool	mm	270	279	289	335	370	400	400	439	425
Input power*	kW	4	6	7	10	13	15	21	25	27
Frequency	blows/min	1150	1600	1700	1500	1310	1420	1550	1450	1137
Total length with tool, without top bracket	mm	865	897	926	1036	1182	1263	1379	1499	1550
Oil flow	l/min	12 - 23	15 - 30	17 - 35	25 - 50	30 - 65	40 - 75	55 - 100	70 - 120	75 - 125
Working pressure of the hammer	bar	110	120	120	120	120	120	125	125	130
Acceptable back-pressure	bar	20	35	32	32	30	30	20	20	20
Clip Bucket		-	•	•	•	•	•	-	-	-
Clip Ram		-	•	•	•	•	•	-	-	-

* Possible increase of the hammer's power by 50% thanks to the energy recovery system.



Montabert®

Montabert: an international presence in more than 100 countries. Optimize the performance of your demolition accessories by contacting our network which is designed to support our products. The Montabert network will provide you with expertise during implementation, maintenance with original spare parts, technical assistance and training.

montabertmarketing@diiattachments.com
www.montabert.com

