

ANROSS

AUTO-SEGREGATOR



RECYCLE!
Re-use waste materials

REDUCE COSTS!

- Reduce disposal costs
Savings on Tipping Charges, Transport Costs and Landfill Tax
- Reduce procurement costs
Recycling gives savings on Material Costs, Transport Costs and Aggregate Levy

APPLICATIONS

- Construction sites
- Recycling & Waste Transfer Stations
- Demolition sites
- Quarrying
- Land Reinstatement
- Horticultural

FEATURES & BENEFITS

- Fully automatic operation, using the hydraulic breaker circuit.
- Dual width gaps - allowing production of alternative sizes of output material
- Self cleaning action.
- Lubricated and shielded drive system.
- Manufactured from **Hardox** steel for high strength and wear resistance.
- Low maintenance
- Interchangeable mounting brackets - allows for use on multiple excavators
- Designed and manufactured in the United Kingdom



"AUTO-SEGREGATOR" Model Reference	AS 80	AS 150	AS 200
Excavator Weight (Tonnes)	5 - 9	8 - 15	13 - 21
Approximate Operating Weight (Kgs) (Including Mounting Bracket)	580	1250	1500
Screening Gap - Rib Removed - E (mm)	62	80	100
Rib Fitted - F (mm)	25	30	35
Throughput * (Cubic Metres / Hour)			
Rib Removed	16 - 30	30 - 60	40 - 80
Rib Fitted	8 - 15	15 - 30	20 - 40
External Width - A (mm)	1120	1470	1700
Internal Width - B (mm)	780	1120	1330
Height - C (mm)	760	900	970
Depth - D (mm)	850	1050	1120
Loading Capacity (Cubic Metre SAE)	0.31	0.6	0.85
Oil Flow (Min / Max) (LPM)	75 - 95	80 - 100	100 - 110
Excavator Supply Line Pressure (Bar)	210	210	210
Note: * Throughput rates are dependent upon the materials being screened. The figures quoted are typical of those achieved in service and are supplied for guidance purposes only.			

Anross Ltd has a policy of constant product development and enhancement. We reserve the right to modify our product designs and specifications without prior notice.

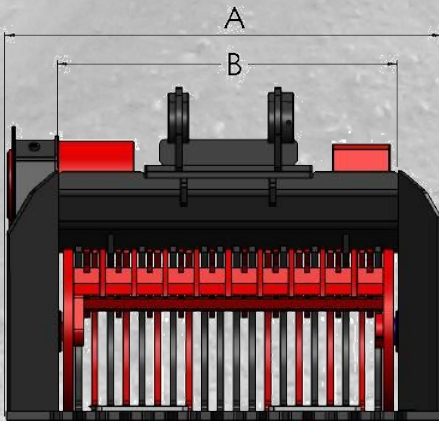

Model AS 200 shown.

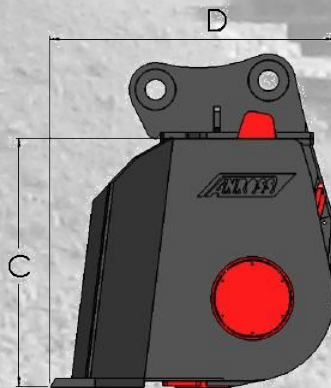

Dual Width Screening Gaps

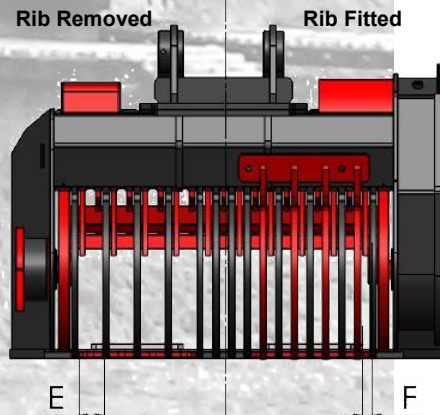

Manufactured by:
Anross Limited
 Lope Hill Road, Leadgate Industrial Estate, Consett
 Co. Durham DH8 7RN United Kingdom
 Tel: +44 (0)1207 509448 Fax: +44 (0)1207 592158
 Web: www.anross.co.uk e-mail: sales@anross.co.uk