

ANROSS

"SELECTA"

GRAB

BUCKET



LOAD



DIG

GRADE

and now **GRIP** a "SELECT-A-TOOL"

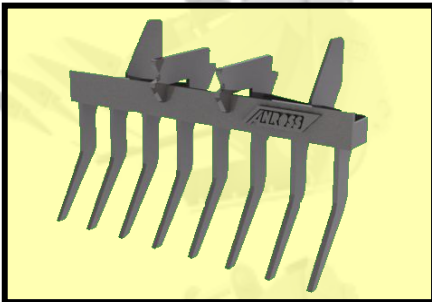

FEATURES

- Multi-functional - increases the flexibility of your excavator
- **NEW!!!** Various attachments available to use with the "Selecta" Bucket.
- Anross Vari-Centre QH mounting system as standard. Alternative mountings also available to order

- **HARDOX** WEAR PLATE used extensively in construction giving high strength and wear resistance for longer life
- Replaceable edges on grab section
- Low maintenance
- British made and designed



MORE THAN JUST A BUCKET!

"SELECTA" BUCKET

TECHNICAL SPECIFICATIONS

"SELECTA" Model Reference	SB 50	SB 80	SB 150	SB 200
Excavator Weight (Tonnes)	3 - 6	6 - 10	12 - 17	18 - 22
Standard Bucket Width - A (mm)	600	750	900	1100
Bucket Depth - B (mm)	720	980	1100	1260
Bucket Height - C (mm)	730	950	1080	1200
Struck Radius - D (mm)	745	1040	1080	1190
Opening - E (mm)	501	800	1040	1140
Weight of Bucket (Approx) (Kgs)	190	400	650	1000
Capacity (Struck) (Cubic Metre)	0.1	0.22	0.38	0.6
Capacity (Heaped SAE) (Cubic Metre)	0.15	0.3	0.47	0.74
Operating Pressure (Bar)	100 - 150	100 - 150	100 - 150	100 - 150

Note: Two-way flow hydraulic circuit required

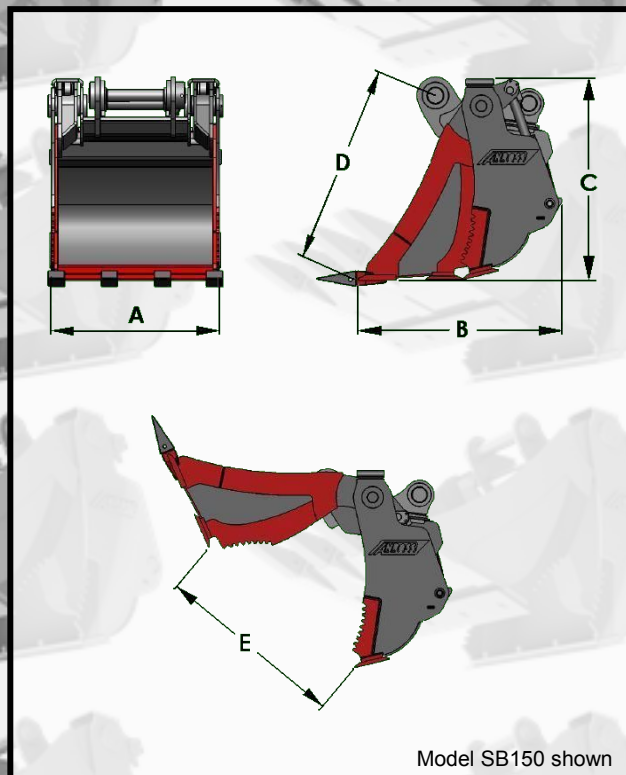

Anross Ltd has a policy of constant product development and enhancement.
We reserve the right to modify our product designs and specifications without prior notice.

SELECT-A-TOOLS

Screening Plate

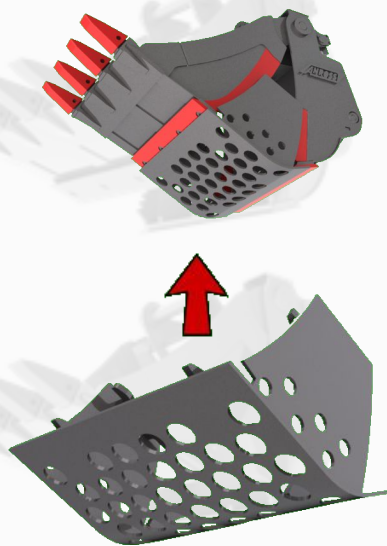

Brushwood Rake

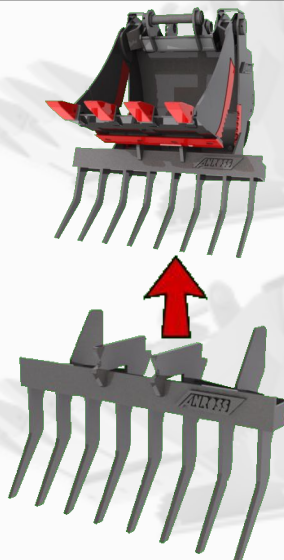

Other options

- Ripper Hook
- Grading Blade
- Brush
- Asphalt Cutting Wheel
- etc...

ANROSS

Manufactured by:

Anross Limited

Lope Hill Road, Leadgate Industrial Estate, Consett
Co. Durham DH8 7RN United Kingdom

Tel: +44 (0)1207 509448 Fax: +44 (0)1207 592158

Web: www.anross.co.uk e-mail: sales@anross.co.uk